

## TYPE: DS485DIS



# DS485DIS Bulkhead Display for use with MantraBUS DSC/DCELL

## Description

The DS485DIS is an LED display module allowing the connection and summing of up to eight DSC or DLC devices. The display enables the use of DSC or DCELLs without the need for permanent connection to a PC or PLC.

The display can toggle between gross and zeroed net display and optionally allows the user to cycle through the individual displays that form the sum. The inputs are all synchronised so the summed display is a true representation of the instantaneous input without skew.

The display can connect to various RS485 DSC and DLC devices with the MantraBUS II protocol. Suitable devices are the DIS4SMAN, DSC4HMAN, DLCSMAN and DLCHMAN. The DSC and DLC devices must have sequential station numbers from 1 to the total number of devices. The default baud rate is 115200.

The module is configured using an RS232 connection to a PC or laptop and Instrument Explorer software. LCM Systems can supply this configured as part of a system complete with sensors, including embedded DCELLs or external DSCs. Please contact our technical team to discuss your requirements.

## Specification

Supply voltage	8 to 18 Vdc
Current consumption (no modules connected)	200mA max
Communications Module Communications BUS	RS485 (8 data bits, 1 stop bit, no parity)
Configuration BUS	RS232 (8 data bits, 1 stop bit, no parity)
Display	6 digit red LED (20mm high digits)
Enclosure	Light grey ABS, with 2 off IP68 cable glands
Terminals	2.5mm saddle field terminals
Accessibility	All electronics and connections accessible by removing lid
Environmental protection	IP65
Storage temperature	-20 to +70°C
Operating temperature	-10 to +50°C
Relative humidity	95% maximum non condensing
Low Voltage Directive	2006/95/EC
EMC Directive	2004/108/EC

## Features

- Displays up to 8 MantraBUS DSC or DCELLS
- Display summed or individual results
- Removes the need for DSC/DLC to be permanently connected to a PC or PLC
- Synchronised sampling across devices
- Gross/net toggle
- Easy to operate toggle buttons
- 6 digit 20mm LED display in red
- Sealed to IP65
- Bulkhead mounted

## Typical Applications

- Vessel weighing
- Tank farm weighing
- Container crane weighing
- Corner weight scales

### LCM Systems Ltd

Unit 15, Newport Business Park  
Barry Way, Newport  
Isle of Wight PO30 5GY UK  
Tel: +44 (0)1983 249264  
Fax: +44 (0)1983 249266  
sales@lcmsystems.com  
www.lcmsystems.com

# DS485DIS Bulkhead Display for use with MantraBUS DSC/DCELL

## Dimensions

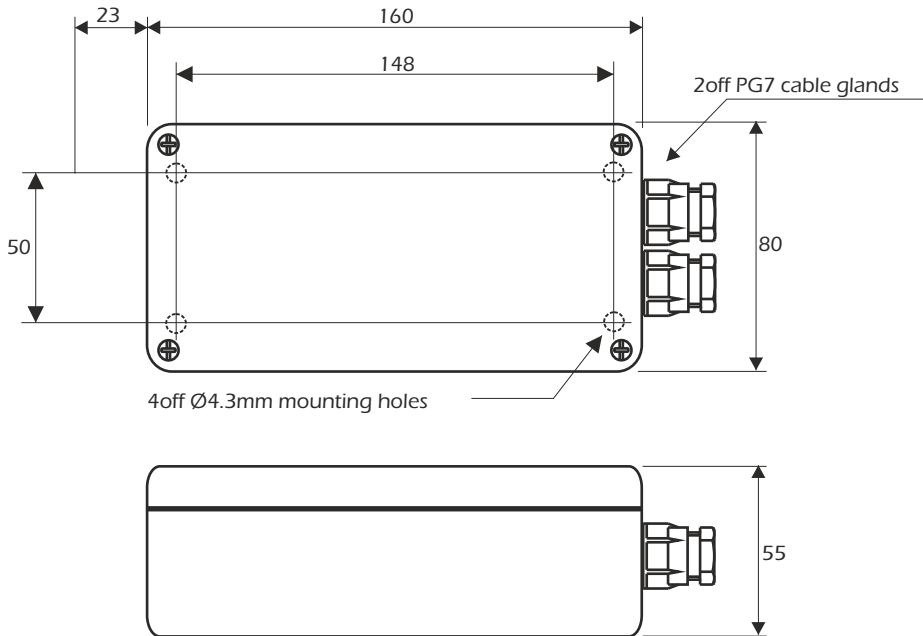

All dimensions are in mm



www.lcmsystems.com

Due to continual product development, LCM Systems Ltd reserves the right to alter product specifications without prior notice.

Issue No. 1

Issue date: 28/03/2015

APPROVED

(unapproved if printed)