

TYPE: SGA



SGA Analogue Strain Gauge Load Cell Amplifier

Description

The SGA A/D strain gauge signal conditioning module is a high performance signal conditioner for load cells that offers a wide bandwidth and a wide input signal range. Both the 110/230Vac powered SGA/A and 18-24Vdc powered SGA/D provide 10volt on-board excitation, capable of powering up to four 350ohm strain gauge bridges. Please note that the 110/230Vac version can also be DC powered.

With an input sensitivity range of ± 0.06 to ± 30 mV/V. Any sensor in this input range can be amplified to give $\pm 10V$, $\pm 5V$, 0-10V, 0-5V, 0-20mA or 4-20mA outputs.

There is also a wide offset control, using a combination of switches and a potentiometer. This gives an adjustment range of $\pm 70\%$. The SGA is an ideal product for many OEM customers, as its flexibility means that it can be configured to suit most applications.

The SGA can be supplied calibrated with any of LCM Systems sensor range or could be integrated within a larger instrumentation system.

Specification

Power supply (SGA/A) 110/230Vac, 50-60Hz	110/230V AC
Power supply DC	18 to 24V (18V max at full load)
Power supply current DC (depends on loading)	50 to 200mA (90mA typical)
Bridge excitation 350R Bridge	9.5 to 10.25V DC (10 DC typical)
Bridge resistance	85 Ω
Bridge sensitivity (switchable)	0.06 to 30mV/V (2.5mV/V typical)
Gain adjustment (Pot - fine adjustment)	0.06 to 1mV/V
Offset adjustment (Pot - fine adjustment)	-1.25 to +1.25%FR
Offset adjustment (Switchable - course adjustment)	± 1.25 to $\pm 79\%$ FR
Output load (Voltage output)	2mA
Output load (Current output)	0 to 500 Ω
Bandwidth (No filter and >2 mV/V) -3dB point	DC to 6kHz
Filter cut-off (Switchable ranges) -3dB point	1 to 5000Hz
Zero temperature coefficient (@2.5mV/V)	0.009%/°C (@2.5mV/V)
Span temperature coefficient	0.01%/°C
Linearity	0.03%FR
Gain stability (1st 1000 hours)	0.2%FR
Gain stability (2nd 1000 hours)	0.1%FR
90 day offset stability	3.3uV
Output load stability gain (0-100%)	0.01%FR
Output load stability offset (0-100%)	0.01%FR
Power supply rejection gain (0-100%)	0.01%FR
Power supply rejection offset (0-100%)	0.01%FR
Operating temperature range	-10 to +50
Storage temperature range	-20 to +70
Humidity	95%
Output options set by on board switch	$\pm 10V$, $\pm 5V$, 0-10V, 0-5V, 0-20mA, 4-20mA
Connections	Field screw terminals - 2.5mm ² rising clamp
Enclosure	ABS case sealed to IP67, fitted with 3 off cable glands
Low voltage directive	2006/95/EC
EMC directive	2004/108/EC

Features

- Very stable bridge excitation
- Selectable sensitivity
- High frequency filtering
- User selectable analogue outputs
- IP67 ABS field case with cable glands
- Wide range filtering - 1Hz to 5kHz
- Switch selectable offset $\pm 70\%$ FS
- Shunt calibration facility (120Kohms)
- Excitation: regulated 10V@110mA

Typical Applications

- Force measurement systems
- Interface sensors to chart recorders
- Simple weighing systems
- Conversion of load cell signals for long cable run applications

LCM Systems Ltd

Unit 15, Newport Business Park
Barry Way, Newport
Isle of Wight PO30 5GY UK
Tel: +44 (0)1983 249264
Fax: +44 (0)1983 249266
sales@lcm systems.com
www.lcm systems.com

SGA Analogue Strain Gauge Load Cell Amplifier



Controls

- ⊙ Gain pot
- ⊙ Offset pot
- ⊙ Course gain switches
- ⊙ Course offset switches
- ⊙ Filter cut-off switches
- ⊙ Output mode switch

Dimensions

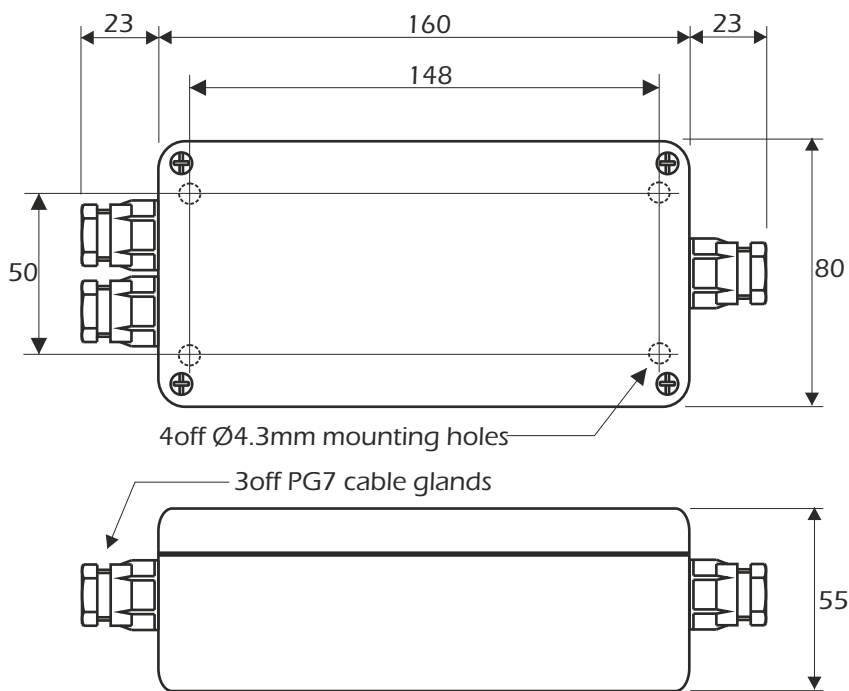

All dimensions are in mm

Order Codes

SGA/A	110/230V ac and/or 18-24V dc powered
SGA/D	18-24v dc powered

Options Available

DIN Rail Mounting Version	Order code - D4
Isolated DC Power Option (9-36V DC)	Order code IS1224

www.lcmsystems.com

Due to continual product development, LCM Systems Ltd reserves the right to alter product specifications without prior notice.

Issue No. 2

Issue date: 04/04/2017

APPROVED

(unapproved if printed)