

TYPE: RILL



RILL Wireless Load Link

Description

The LCM RILL series have been designed for lifting and weighing in rugged or harsh environments. Being manufactured from high tensile aluminium to minimise weight also makes them ideal for mobile use (steel brushed holes provide added wear protection from shackles etc).

The RILL load link range is simple to install and are matched to standard shackle sizes. They are supplied complete with a battery powered handheld indicator, which will display the load in tonnes or pounds (other measurement units are available on request). The handheld indicator is very easy to operate, with just three buttons. One turns the unit On/Off, one toggles between Gross/Net, and the third allows you to switch units from tonnes to pounds and vice versa.

The RILL can be supplied as a simple load link or as part of a more complex telemetry system. Please contact our technical engineers to discuss any specific requirements you may have.

Specification

Rated load (tonnes)	1, 2.5, 5, 12, 25, 35, 50, 75, 100, 150, 200, 250, 300
Proof load	200% of rated load
Safety factor	500% of rated load (1, 2.5, 5, 12, 25, 35, 50, 75, 200 te) 400% of rated load (100, 150, 250, 300 te)
Display (T24-HS)	7 digit LCD, 9mm high digits
Accuracy	<±0.1% of rated load
Power supply	4 x AA alkaline batteries for load link 2 x AA alkaline batteries for T24-HS display
Battery life	850 hours continuous use for load link 400 hours continuous use for T24-HS display
Transmission range	700 metres (clear line of sight)
Radio frequency	2.4GHz
Update rate	Standard is 1 per second
Operating temperature range	-10 to +50°C
Compensated temperature range	-10 to +50°C
Zero temperature coefficient	<±0.02% of rated load/°C
Span temperature coefficient	<±0.02% of rated load/°C
Environmental protection level	IP67

Available Options

- Wireless overload alarm module
- Wireless base station with analogue output
- Wireless signal booster
- Multiple wireless load cell controller software
- Wireless slave display
- Crosby shackle supply

Features

- Ranges from 1 to 300 tonnes
- Lightweight aluminium construction
- Shackle holes are steel brushed
- Environmentally sealed to IP67
- License Free 2.4GHz radio
- Internal antennae
- Over 800 hours batter life using standard AA batteries
- Can be supplied with various bespoke telemetry and/or software packages

Typical Applications

- Underhook crane weighing
- Cable tension monitoring
- Crane/hoist proof loading
- Water weights calibration
- Warehouse despatch weighing

AVAILABLE TO BUY ONLINE

Visit our website www.lcmsystems.com
(In-stock items usually ship within 48 hours)

LCM Systems Ltd

Unit 15, Newport Business Park
Barry Way, Newport
Isle of Wight PO30 5GY UK
Tel: +44 (0)1983 249264
Fax: +44 (0)1983 249266
sales@lcmsystems.com
www.lcmsystems.com

RILL Wireless Load Link

Dimensions

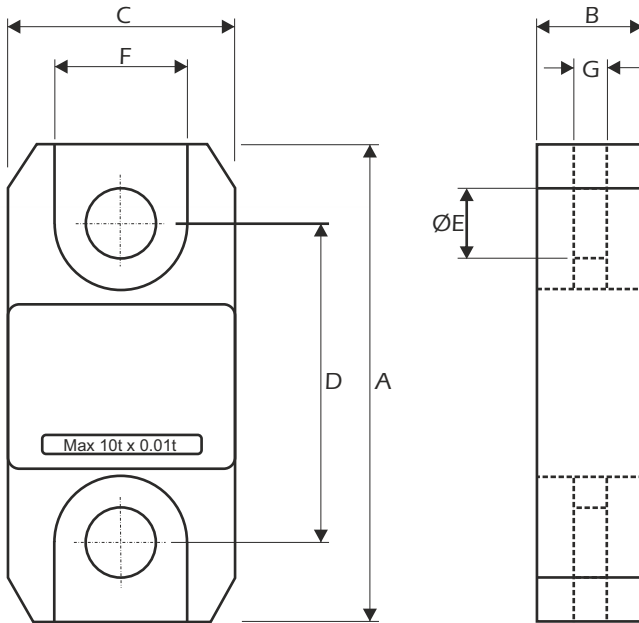

All dimensions are in mm

Rating (tonnes)	A	B	C	D	ØE	F	G	Resolution (tonnes)	Resolution (lbs)	Weight (kg)
1	204	43	101	146	24.5	48	19	0.0005	1	1.5
2.5	204	43	101	146	24.5	48	19	0.001	2	1.5
5	249	43	101	165	38	66	32	0.001	2	2.2
12	305	47	101	193	47.5	N/A	N/A	0.002	5	3.5
25	340	60	115	215	55	N/A	N/A	0.005	10	5.2
35	393	75	126	225	60	N/A	N/A	0.005	10	9
50	424	75	163	230	76	N/A	N/A	0.01	20	11
75	470	75	202	260	76	N/A	N/A	0.01	20	18
100	608	99	255	320	109	N/A	N/A	0.05	100	37
150	670	99	303	360	109	N/A	N/A	0.05	100	51
200	700	144	320	350	132	N/A	N/A	0.1	200	80
250	700	144	320	350	132	N/A	N/A	0.1	200	80
300	806	150	426	350	160	N/A	N/A	0.1	200	132

Display

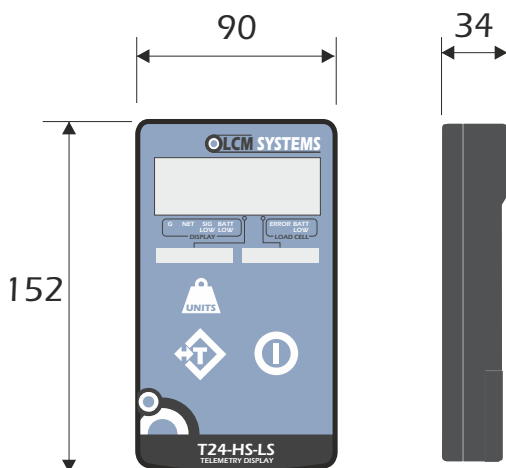

www.lcmsystems.com

Due to continual product development, LCM Systems Ltd reserves the right to alter product specifications without prior notice.

Issue No. 4

Issue date: 18/10/2016

APPROVED

(unapproved if printed)