

TYPE: LCD20



LCD20 Intelligent Strain Gauge Load Cell Amplifier

Description

The LCD20 intelligent strain gauge bridge amplifier is a compact, stackable microprocessor based unit specifically designed to control and monitor process applications. It offers flexible connection to most load cells, pressure or strain gauges over a wide range of sensitivities. The unit provides isolated current 4-20mA and voltage 0-10V analogue outputs and two digital inputs.

Two set point relays can be configured to set thresholds such as net, gross, peak and valley. Powered from a wide ranging DC supply, the DIN rail amplifier is supplied with 2 part screw connectors for ease of installation.

The LCD20 will support 6 wire input to compensate for barrier and cable losses. It is factory calibrated to mV/V and allows 10 point user calibration to the desired engineering units. Configuration options are achieved via a handheld programmer or PC Toolkit software.

The analogue outputs and relays interface to existing acquisition and control systems, making this unit an ideal partner for any integrated instrumentation system.

Specification

Isolated power supply	9 to 32 Vdc
Power	2.5W typical
Bridge excitation	4.75 to 5.25V
Bridge resistance (minimum for 5V excitation)	85 Ohms
Bridge sensitivity	0.5 to 7.8 mV/V
Resolution	1:180,000 (17.5 Bits)
Analogue outputs	4.20mA and 0-10V
Analogue output resolution	1:8000 (13 Bits)
Relays	2 off SPNO
Relay countacts rating	3A 240V AC / 3A 30V DC
Isolation	+/- 130V RMS or DC to any port
Operating temperature range	-20 to 70°C
Storage temperature range	-20 to 90°C
Maximum humidity	95% non-condensing
IP rating	IP20
EMC Directive	2014/30/EU
Low Voltage Directive	2014/35/EU
EMC standards	BSEN 61326-1:2013
Low voltage standards	BSEN 61010-1:210

Order codes

Load cell amplifier in DIN enclosure	LCD20
Handheld programmer	LP2
Programming cable for Toolkit	PGM1

Features

- Standard analogue outputs (4-20mA and 0-10V)
- 2 single pole relays and digital inputs as factory standard
- Provides controls and alarms without the need for additional instrumentation
- 10 point linearisation provides superior accuracy
- Full digital setup and easy programming via a handheld unit or USB connection to a PC
- Lockable features prevents loss of device settings
- Configuration can be saved and restored

Typical Applications

- Vessel weighing
- Silo weighing
- Batch control
- Crane overload protection/ weighing
- Force measurement

LCM Systems Ltd

Unit 15, Newport Business Park
Barry Way, Newport
Isle of Wight PO30 5GY UK
Tel: +44 (0)1983 249264
Fax: +44 (0)1983 249266
sales@lcm systems.com
www.lcm systems.com

LCD20 Intelligent Strain Gauge Load Cell Amplifier

Dimensions

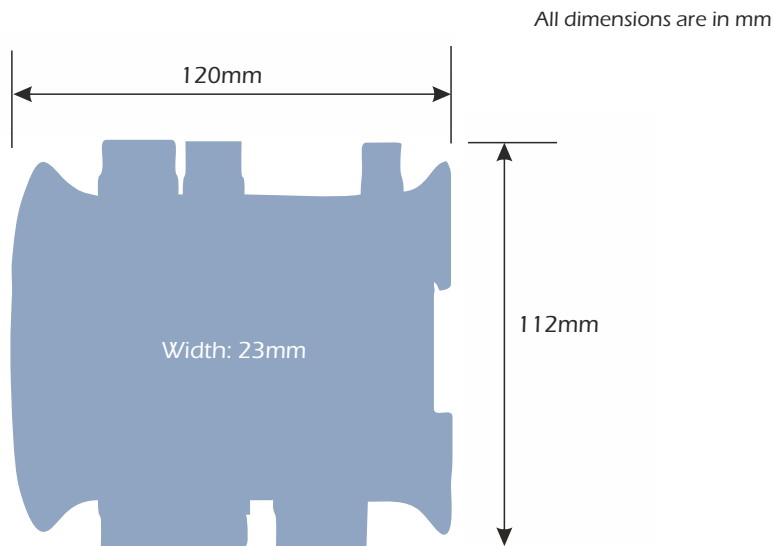

Electrical

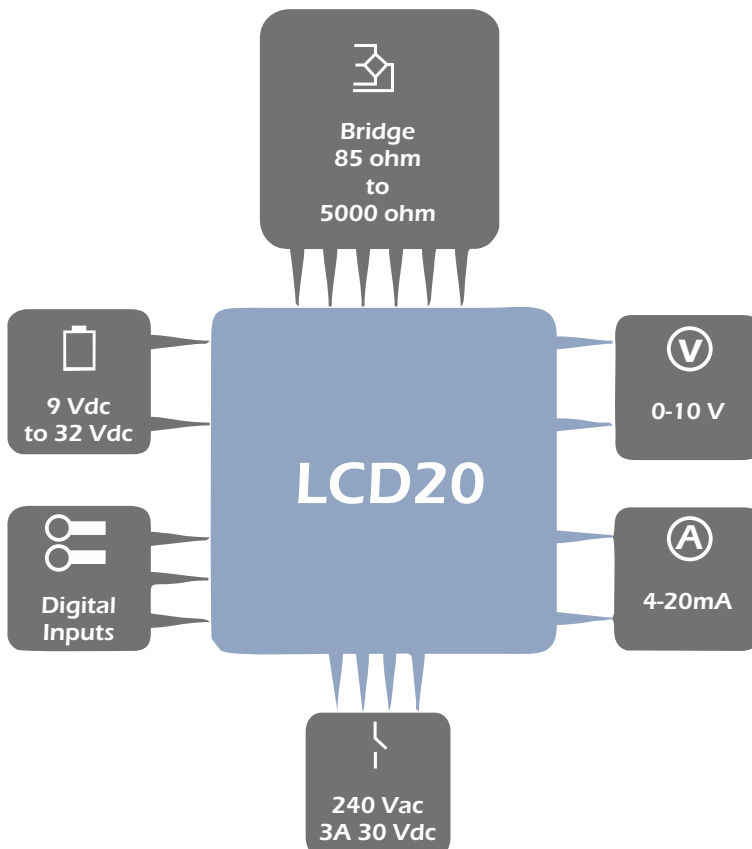

www.lcmsystems.com

Due to continual product development, LCM Systems Ltd reserves the right to alter product specifications without prior notice.

Issue No. 1

Issue date: 02/10/2019

APPROVED

(unapproved if printed)