

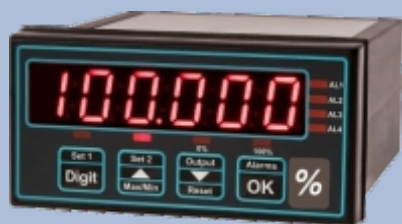

TYPE: PMD-SERIAL



PMD-SERIAL RS232 & RS485 Input Panel Mounting Slave Display

Features

- RS232 or RS485 serial input
- Menu free setup and calibration
- 14.2mm high red LED display
- AC or DC powered versions
- Wide choice of analogue, relay or digital outputs
- All option boards are pluggable and can be retro-fitted
- IP65 sealed (option for IP67 sealing)

Typical Applications

- Vessel weighing
- Winch monitoring
- Crane weighing
- Module weighing
- General force measurement

Description

The PMD-SERIAL is a panel mounting display which can be connected to an RS232 or RS485 ASCII serial bus, primarily for use as a remote slave display, and offers very simple operation and configuration. The PMD-SERIAL does not use a menu system to configure and calibrate the display, making installation and commissioning very straightforward.

To simplify commissioning even further, the product instruction manual provides step by step pictorial details for each function that you may want to configure, saving time searching through an overly complex manual to try to find that one parameter you wish to change.

The main application for the PMD-SERIAL is for simple crane weighing applications, hoist and winch monitoring, as well as many other force measurement applications.

Different input signals are available including load cell/strain gauge bridge input (see PMD-STRAIN) and process input (see PMD-PROCESS). LCM Systems engineers will be pleased to discuss your specific application requirements with you. They will be able to advise on the correct product selection, options required and advise on suitable sensors, where required.

Specification

Power supply	95-265vac (optional 11-30V DC)
Power rating	10 VA maximum
Input signals	RS232 (with S2 input option) RS485 (with S4 input option)
Display range	-199999 to +199999
Connections	All user/installation connections using detachable field screw terminals
Case material	Black polycarbonate
Storage temperature	-20 to +70°C
Operating temperature	0 to +50°C
Environmental sealing	IP65 (when mounted in a suitable enclosure)
Weight	300g

Available Options

- Cover (part number SPC4, increasing sealing to IP67)
- Power supply options: 95-265vac and 11-30vdc.
- Input options: RS232 and RS485/RS422
- Output options: 4-20mA, 0-10V, $\pm 10V$, 2 relay alarms, 4 relay alarms, RS232, RS485 or Modbus RTU ASCII.

PMD-SERIAL RS232 & RS485 Input Panel Mounting Slave Display

Dimensions

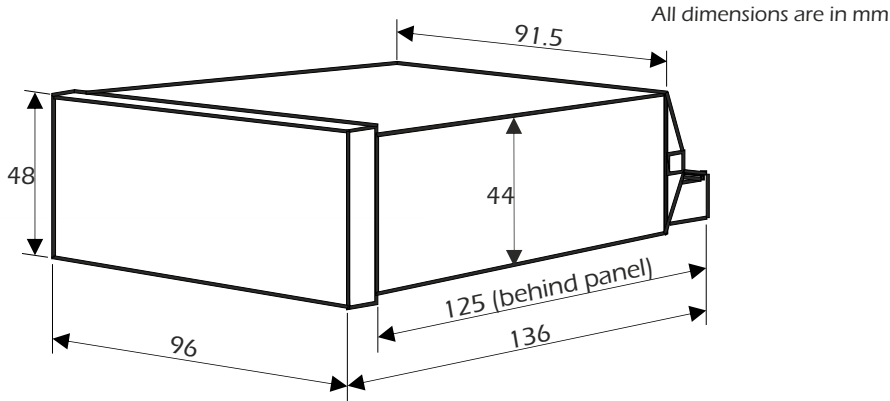

Panel cutout should be 92mm wide x 45mm high, +1mm, -0mm
1/8 DIN. Depth behind panel 125mm max, including cables.

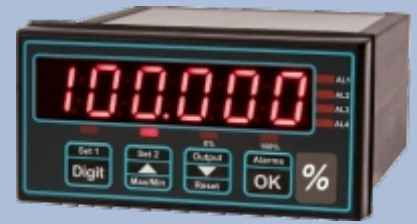

Ordering Guide

Create a full part number like this:-

Model	Input Options	Analogue Output	Alarm Output	Serial Data Output	Supply Voltage
PMD-SERIAL	RS232 -S2 RS484 -S4	No output -0 4-20mA -ANI -10V -ANV ±10V -ANB	No alarms -0 2 alarms -AL2 4 alarms -AL4	No data -0 RS232 -232 RS485 -485 MB RTU -RTU	95-265VAC-AC -AC 11-30VDC -DC

PMD-SERIAL					
------------	--	--	--	--	--

Example - PMD-SERIAL display with RS232 input, 4-20mA output, 2 alarms, RS485 output and 110V AC powered. **Order code will be: PMD-SERIAL-S2-ANI-AL2-485-AC**

www.lcmsystems.com

LCM Systems Ltd

Unit 15, Newport Business Park, Barry Way
Newport, Isle of Wight PO30 5GY UK

Tel: +44 (0)1983 249264

sales@lcmsystems.com

www.lcmsystems.com

Due to continual product development, LCM Systems Ltd reserves the right to alter product specifications without prior notice.

Issue No. 1

Issue date: 28/03/2014

APPROVED

(unapproved if printed)