

TYPE: T24-ACM

T24-ACM Single Channel Telemetry Docking Module



Description

The T24-ACM is a single channel connectivity module offering high precision measurement of a single input. It has a high performance radio/telemetry output when fitted with one of our telemetry acquisition modules.

Usable around the globe on the licence-free 2.4GHz frequency, the T24 range avoids local radio interference to ensure data integrity and security. The system provides exceptional performance in the field with a battery life of up to 5 years, by 'powering down' between transmissions or 'powering off' completely.

Featuring a compartment for a pair of alkaline 'D' cells, the T24-ACM also has a regulator circuitry for an external power supply. The batteries can also be used to provide power in case of external supply failure. For easy wireless sensing, the unit provides connections via the 2 part screw terminals and environmental sealing to IP67.

The T24-ACM high accuracy, low noise measurement electronics deliver high resolution, low drift results which can be user calibrated over 9 points to enable linearization and to deliver results in user definable engineering units. The results can be transmitted at rates of up to 200 per second to other wireless sensing T24 devices such as handheld displays, analogue outputs and base stations etc.

The wireless sensor transmitter is configured and calibrated (either by applying known inputs or by table entry) using free T24 Toolkit software which runs on a PC connected to a T24 base station.

The T24 offers a wireless range of up to 800 m (2,600 ft) in open field site.

For use in any measuring application, from torque to weight, vibration to flow, the T24-ACM offers users a complete solution.

Specification

Battery supply voltage	2.1Vdc to 3.6Vdc (3Vdc typical)
External power supply voltage	5-18Vdc or 2 x D cell
Battery life at 1 transmission per second	1 year
IP rating	IP67
Operating temperature	-20 to +55 °C
Storage temperature	-40 to +85 °C
Humidity	0 - 95%RH
Case dimensions	164 x 84 x 57mm
Case material	ABS
Terminals	2.5mm rising clamp field terminals
Cable size	Ø4 to 8mm
Accessibility	All electronics accessible by removing lid

Order Codes

- Single channel strain acquisition: **T24-ACM-SA**
- Single channel voltage acquisition: **T24-ACM-VA**
- Single channel current acquisition: **T24-ACM-IA**

Features

- Screw terminals for ease of connection
- Powered by self-contained batteries for up to 5 years
- Regulated external supply
- Simple configuration of acquisition module via PC using a base station and telemetry toolkit software
- Integrated PCB antenna
- Remote power 'on' and 'off'
- IP67 sealed enclosure

Typical Applications

- Crane weighing and overload protection
- Production machining condition monitoring
- Vessel weighing
- Vehicle weighing

LCM Systems Ltd

Unit 15, Newport Business Park
Barry Way, Newport
Isle of Wight PO30 5GY UK
Tel: +44 (0)1983 249264
Fax: +44 (0)1983 249266
sales@lcm systems.com
www.lcm systems.com

T24-ACM Single Channel Telemetry Docking Module

Dimensions

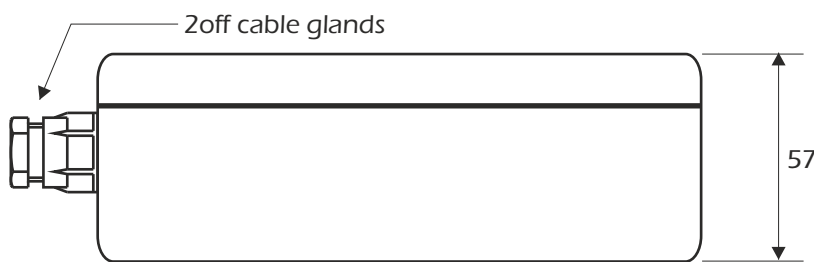
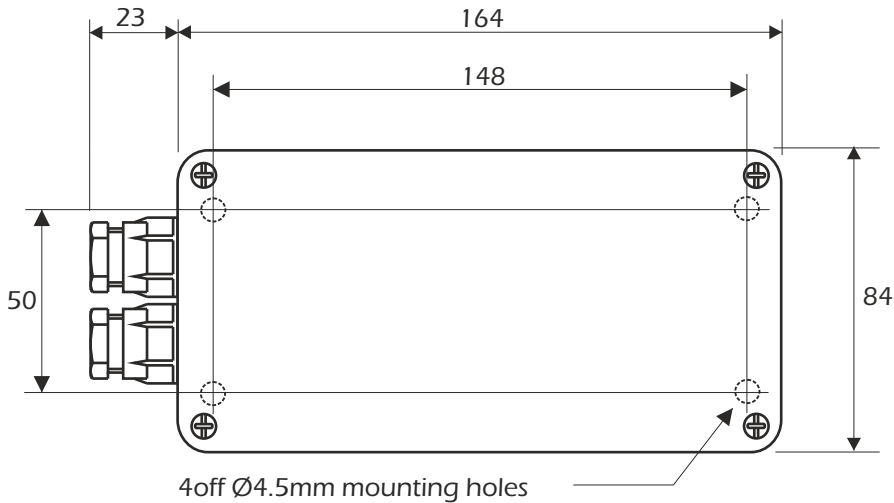

All dimensions are in mm

