

TYPE: T24-ACMi

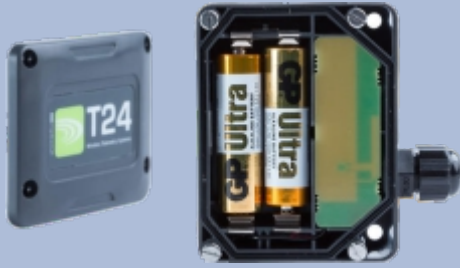

T24-ACMi Single Channel Telemetry Compact Docking Module

Description

The T24-ACMi is a single channel connectivity module offering high precision measurement of a single input. It has a high performance radio/telemetry output when fitted with one of our telemetry acquisition modules.

Usable around the globe on the licence-free 2.4GHz frequency, the T24 range avoids local radio interference to ensure data integrity and security. The system provides exceptional performance in the field with a battery life of up to 5 years, by 'powering down' between transmissions or 'powering off' completely.

The T24-ACMi is powered by a pair of alkaline 'AA' cells and is environmentally sealed to IP67.

The T24-ACMi high accuracy, low noise measurement electronics deliver high resolution, low drift results which can be user calibrated over 9 points to enable linearization and to deliver results in user definable engineering units. The results can be transmitted at rates of up to 200 per second to other wireless sensing T24 devices such as handheld displays, analogue outputs and base stations etc.

The wireless sensor transmitter is configured and calibrated (either by applying known inputs or by table entry) using free T24 Toolkit software which runs on a PC connected to a T24 base station.

The T24 offers a wireless range of up to 800 m (2,600 ft) in open field site.

Specification

Battery supply voltage	3 Vdc (2 x AA)
Battery life at 1 transmission per second	5 months
IP rating	IP67
Operating temperature	-20 to +55 °C
Storage temperature	-40 to +85 °C
Humidity	0 - 95%RH
Case dimensions	80 x 62 x 34mm
Case materials	ABS
Terminals	1.5mm rising clamp field terminals
Accessibility	All electronics accessible by removing lid
Power supply	From batteries (2 x AA size Alkaline) Please note these are not included

Order Codes

- Single channel strain acquisition: **T24-ACMi-SA**
- Single channel voltage acquisition: **T24-ACMi-VA**
- Single channel current acquisition: **T24-ACMi-IA**

Features

- Screw terminals for ease of connection
- Exceptionably low power for long battery life (up to 5 years)
- Simple configuration of acquisition module via PC using a base station and telemetry toolkit software
- Integrated PCB antenna
- IP67 sealed enclosure
- Remote power 'on' and 'off'
- High speed - up to 200 updates per second
- High resolution - up to 1 part in 400,000 (18bit)

Typical Applications

- Crane weighing and overload protection
- Production machining condition monitoring
- Vessel weighing
- Vehicle weighing

LCM Systems Ltd

Unit 15, Newport Business Park
Barry Way, Newport
Isle of Wight PO30 5GY UK
Tel: +44 (0)1983 249264
Fax: +44 (0)1983 249266
sales@lcm systems.com
www.lcm systems.com

T24-ACMi Single Channel Telemetry Compact Docking Module

Dimensions

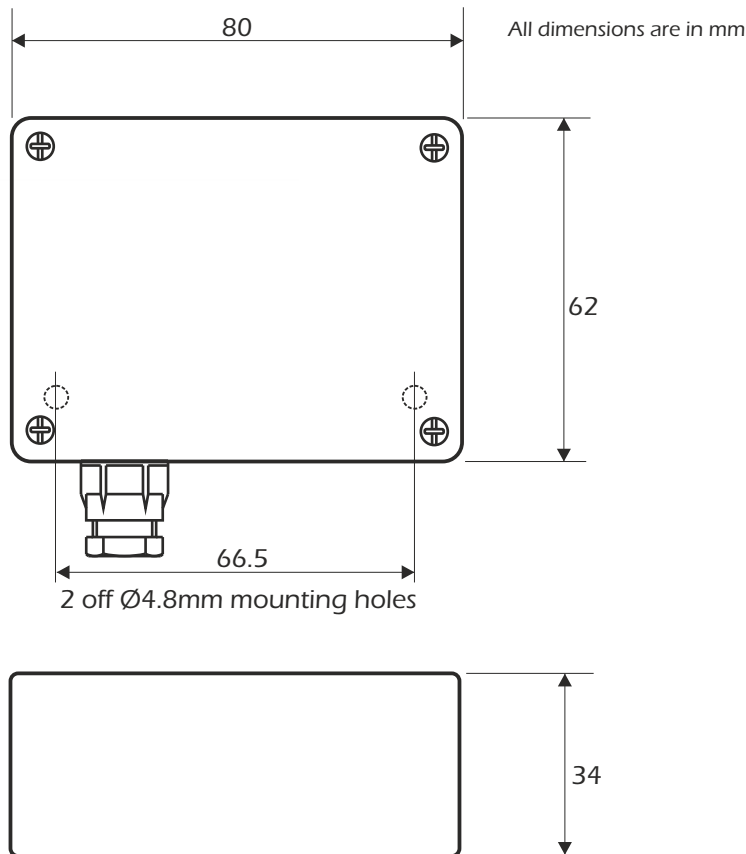

www.lcmsystems.com

Due to continual product development, LCM Systems Ltd reserves the right to alter product specifications without prior notice.

CE Complies with EMC directive. 2004/108/EC

FC The Radio Equipment and Telecommunications Terminal Equipment (R&TTE) Directive, 1999/5/EC. Family: RAD24

Industry Canada Industrie Canada IC:7224A-RAD24

Issue No. 1

Issue date: 28/02/2019

APPROVED

(unapproved if printed)